

## 28KHz/35KHz ultrasonic spot welding gun Operation Manual

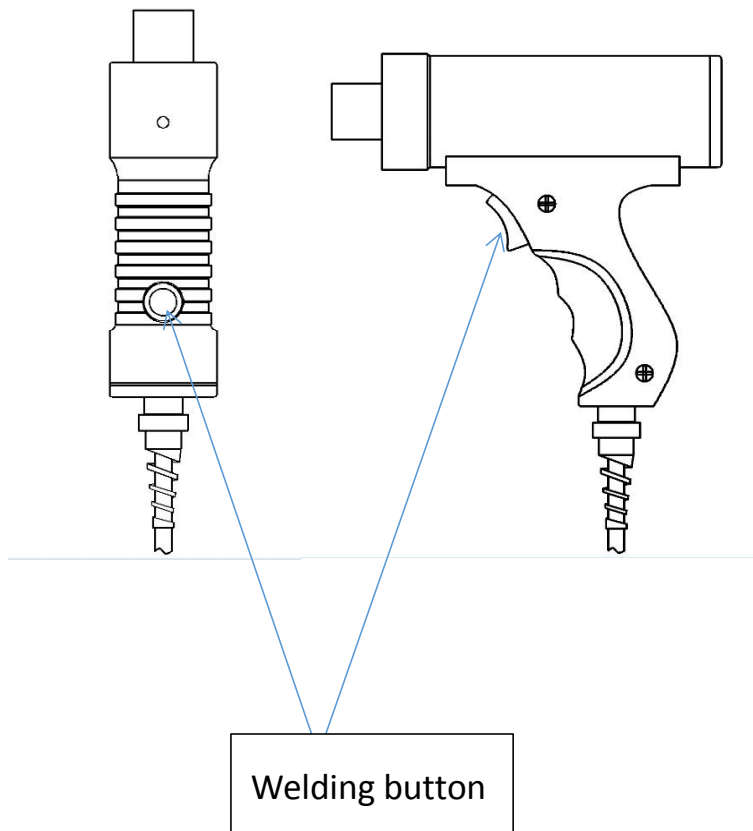

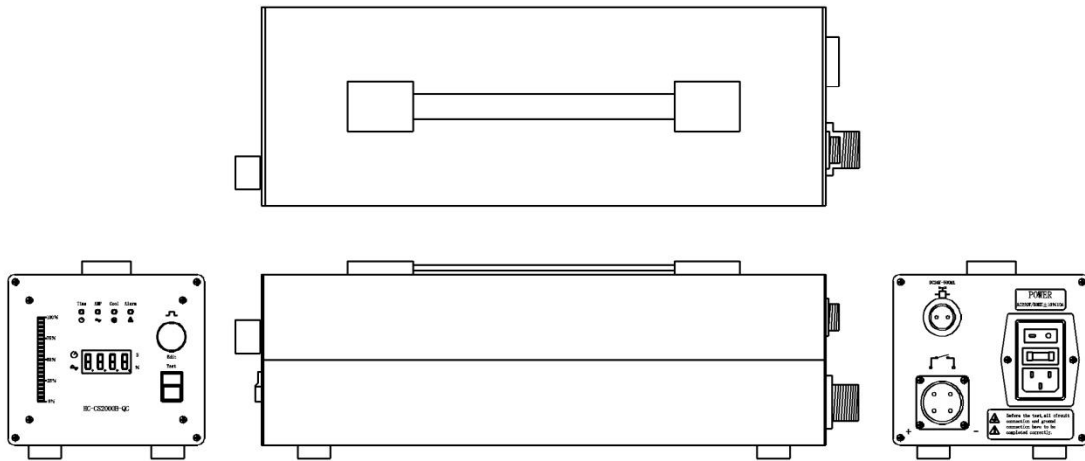
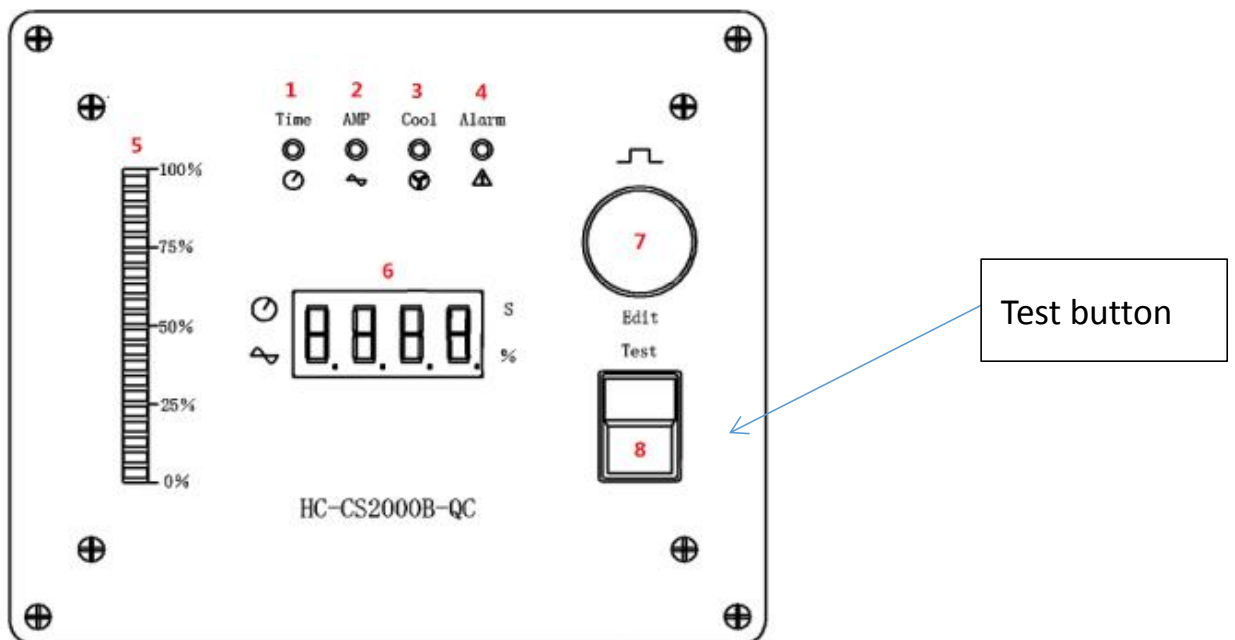
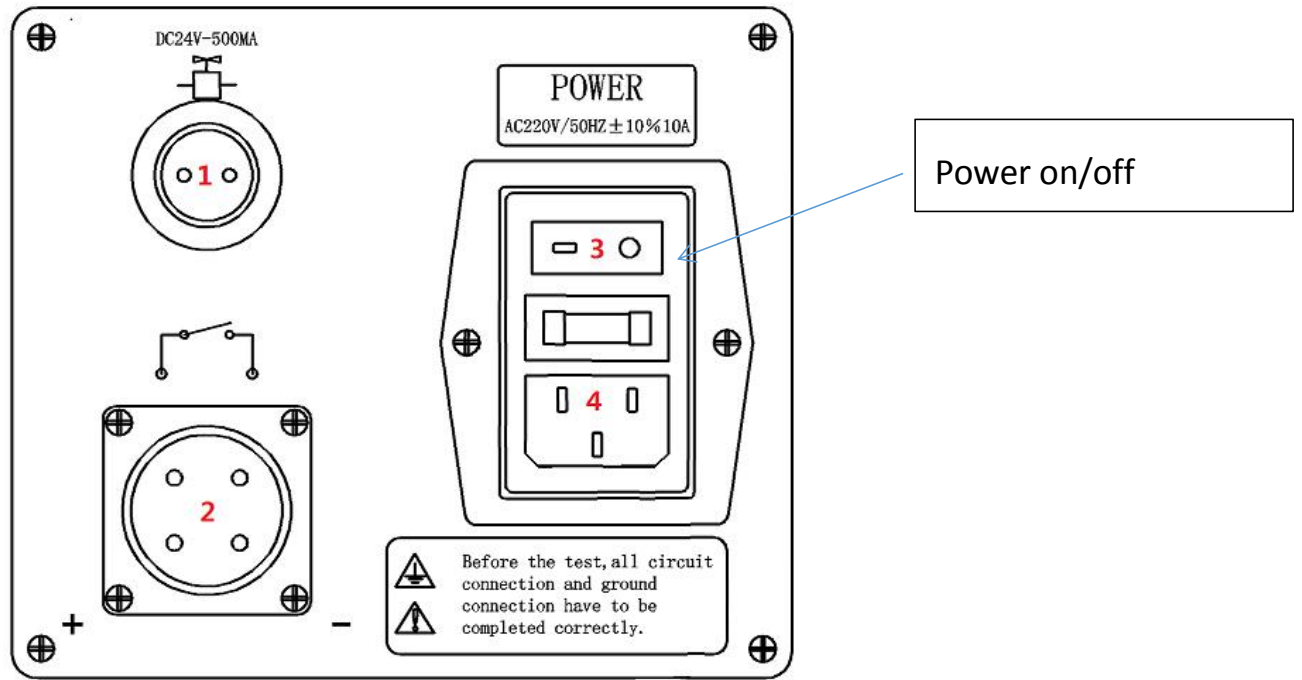

- 1、 Confirm all interface wiring connect correct depending on the generator Instruction manual.
- 2、 Power on/off button 3 to make it power on.
- 3、 Press test button 8 it will tracking frequency itself.
- 4、 Press the button on the handle for welding.

Suitable material: All Thermoplastic material like crylic, ABS, Nylon, PLA, Polybenzimidazole, Polycarbonate, Polyether sulfone, Polyoxymethylene, Polyetherether, ketone, Polyetherimide, Polyethylene, Polyphenylene oxide, Polyphenylene sulfide, Polypropylene, Polystyrene, Polyvinyl chloride, Teflon